

WYZE™ ROBOT VACUUM MANUAL

Please read this manual carefully
before use and store it in a safe place.

CONTENTS



Product Introduction	1
Installation Instructions	4
Operation Instructions	5
Routine Maintenance	8
Basic Parameters	10
Troubleshooting	11
Usage Restrictions	13
Warranty Certificate	14
FCC WARNING	15
IMPORTANT SAFETY INSTRUCTIONS	16

Product Introduction

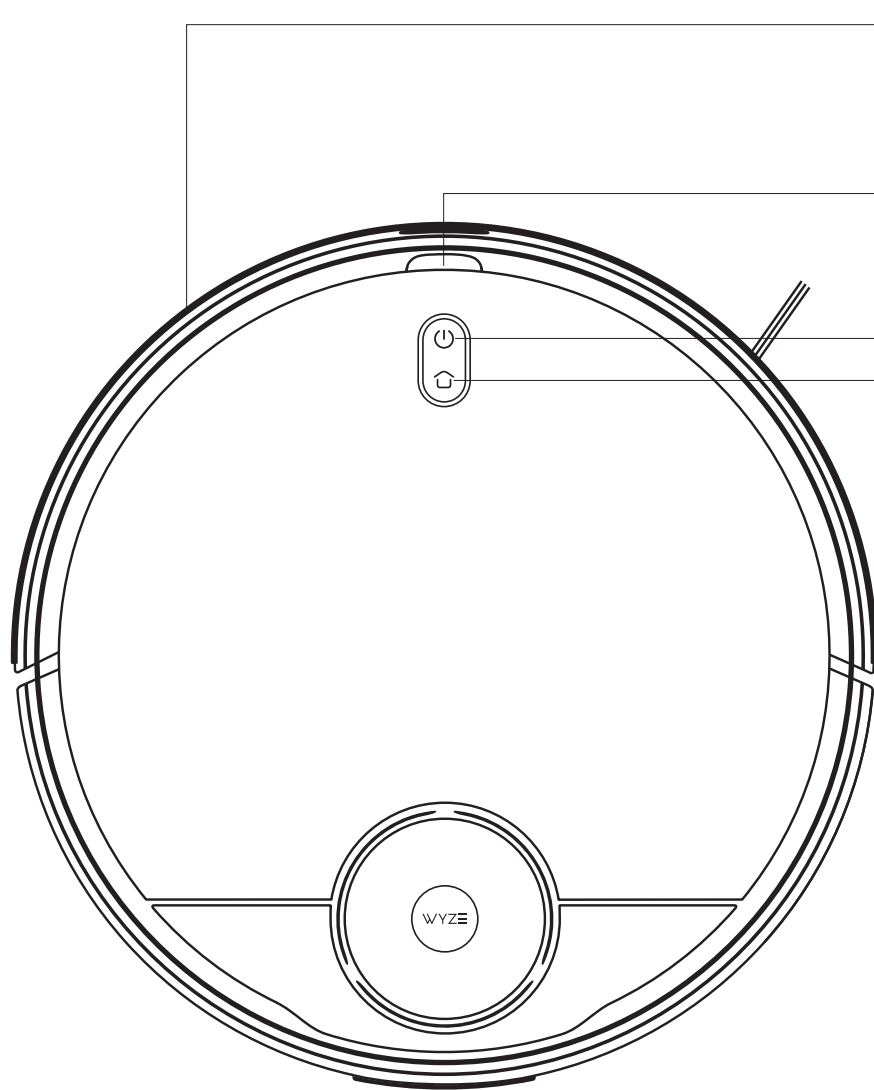
Robot Vacuum



- **WiFi Configuration**

When the vacuum is turned on, press and hold  +  simultaneously for 3 seconds to enter setup mode.

- **Access Point**

The dustbin can be removed by opening the cover from here.

- **Power Button**

Press once to start/pause cleaning.

Press and hold for 3 seconds to power on or shut down the vacuum.

White light remains on: Working normally.

Yellow light blinks slowly: Returning for recharging / Low battery.

Yellow light pulses: Charging.

White light blinks slowly: Entering WiFi configuration mode.

White light pulses: Starting up / Upgrading firmware.

Red light blinks fast: Error.

- **Home Button**

Press this button to return to charging station.

Product Introduction

Robot Vacuum

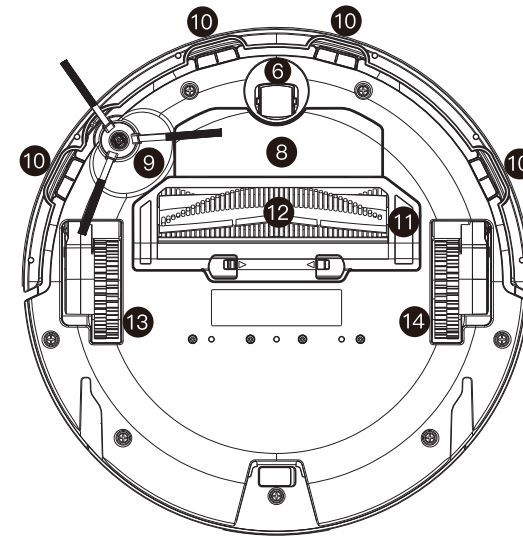
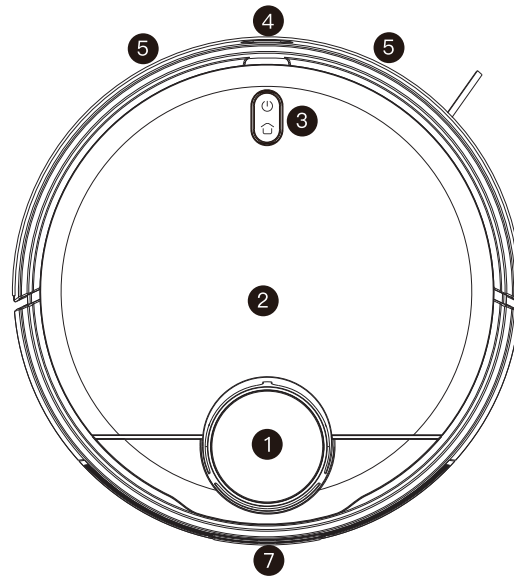

① Laser radar

② Top cover

③ Power and Home Buttons

④ Infrared receiving sensor

⑤ Collision sensor

⑥ Caster wheel

⑦ Charging contacts

⑧ Battery

⑨ Edge brush

⑩ Cliff sensor

⑪ Main brush cover

⑫ Main brush

⑬ Left wheel

⑭ Right wheel

Product Introduction

Charging Station

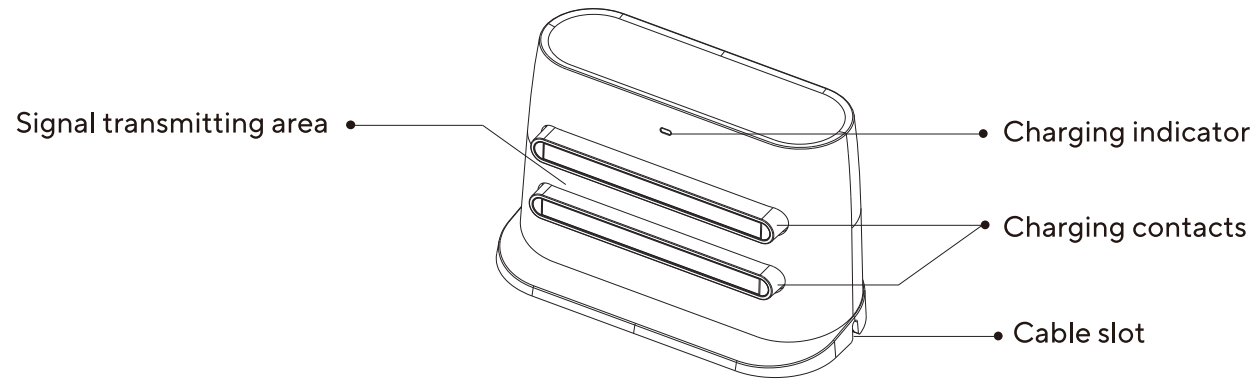

Dustbin

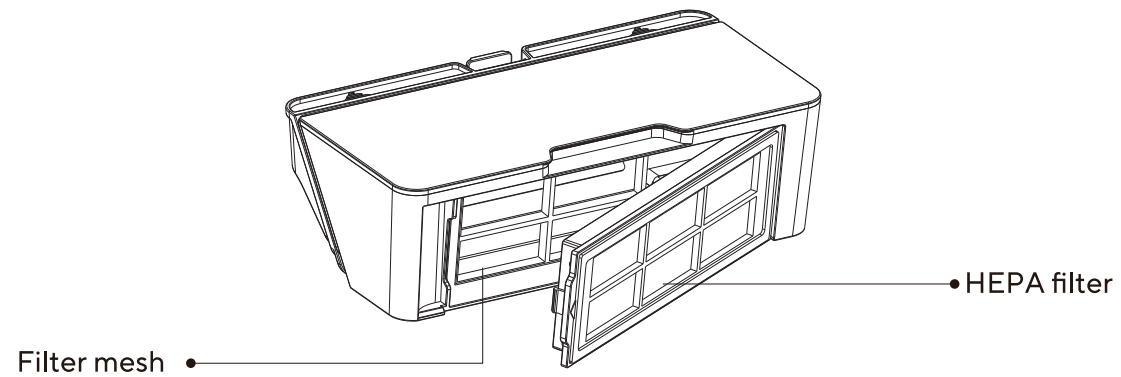

Installation Instructions

1. Connect the power cable and spool the extra cable into the charging station.

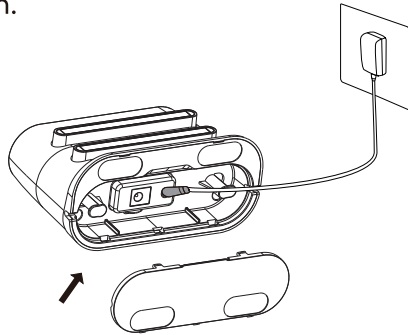

* Please put the extra cable into the cable slot at the bottom of the charging station to prevent the vacuum from running over the cable.

2. Place the charging station against a wall and connect the power supply.

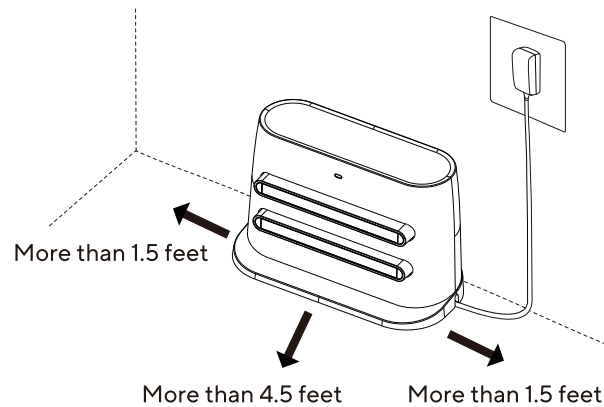

* Leave at least 1.5 feet of room on both the left and right sides of the charging station and at least 4.5 feet directly in front of it.

* Do not expose the charging station to direct sunlight.

3. Turn on and charge.

Place the vacuum on the floor. Press and hold  for 3 seconds and connect the vacuum to the charging station to charge. The expected charging time for the first use is 2 hours.

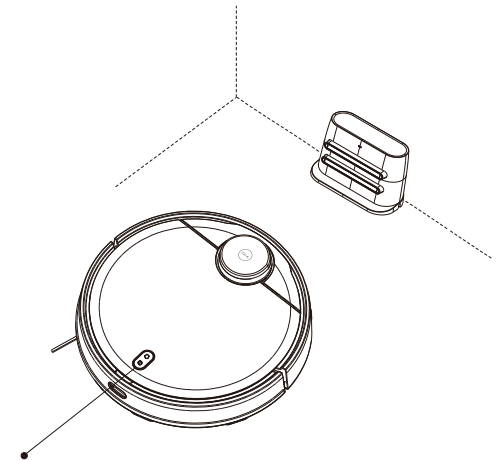

White light stays on	Setup completed
	Working normally
	Fully charged
Yellow light pulses	Charging
Red light blinks fast	Error



* If the battery is low, the vacuum may not start up or return to the charging station. In this case, connect the vacuum to the charging station manually.

* The vacuum will turn on automatically when charging.

* The vacuum cannot be turned off while connected to the charging station.



Operation Instructions

Turn On/Off

- The vacuum will turn on automatically when charging.
- The vacuum cannot turn off while charging.
- Press and hold  the power indicator light will turn on and the vacuum will turn on. The vacuum will say, "Turning on."
- When the vacuum is inactive, press and hold  to turn off the vacuum. The vacuum will say, "Turning off."

Cleaning

Manual Buttons:

- When turned on, press . The vacuum will say, "Start cleaning."
- When turned on, press . The vacuum will say, "Start recharging."

In-App Buttons:

- In the Wyze app, tap **Wyze Robot Vacuum** then **Clean** to begin cleaning. The vacuum will say, "Starting cleaning."
- In the Wyze app, tap **Wyze Robot Vacuum** then **Stop** to send the vacuum back to the charging station.
Once it connects to the charging station, the vacuum will say, "Starting to charge"

* The cleaning function cannot be enabled if the battery is low.

Charging

1. When the vacuum has finished cleaning, it will say, "Cleaning finished." Smart charging will steer the vacuum to the charging station.
2. When the vacuum has a low battery during cleaning, smart charging will bring the vacuum to the charging station automatically. After it is charged, it will resume where it stopped cleaning.
3. The vacuum turns off automatically if it runs out of battery. In this case, manually connect the vacuum to the charging station and ensure that the charging contacts have a good connection.

Operation Instructions

Status Light Guide

Home button light on	The device is powered on
Flashing white light	Connecting to WiFi network
Pulsing white light	The device is starting up/ Upgrading firmware
Solid white light	Standby/ cleaning mode
Flashing yellow light	The device is recharging
Flashing red light	Error/ troubleshooting mode
Home button light off	The device is powered off/ in sleep mode

WiFi Configuration & Firmware Upgrade



Scan the QR code on the Quick Start Guide to download the Wyze app. Follow the instructions to connect your Wyze Robot Vacuum to WiFi.

Note: The vacuum only supports a 2.4GHz network connection. Please select a WiFi network name (SSID) that's on a 2.4GHz band.

- Log into your Wyze app and open the Wyze Robot Vacuum settings. Before updating your firmware, connect your vacuum to the charging station and ensure the battery is charged to at least 30%.
- App unbinding: Press and hold the Home button for 5 seconds and release it when "Factory settings will be restored" is heard. Then Press and hold the Home button again for 5 seconds, and the voice prompt "Restoring factory settings / Factory settings restored successfully" will be heard.

Operation Instructions

Pause

When the vacuum is in operating, press any button to pause. Press  to continue cleaning and press  to return to the charging station and end the current cleaning task.

Sleep

If no operation is performed within 5 minutes, the vacuum will automatically enter Sleep mode. In this mode, you can wake up the vacuum by pressing the button or using the app.

- The vacuum will not enter Sleep mode while it is being charged on the charging station.
- The vacuum will shut down automatically when the sleep time exceeds 6 hours.

Error Mode

In case of any abnormality during operation, the red button light will blink fast and a voice prompt will be heard.

For solution, please see the "Troubleshooting" section of this manual.

- If no operation is performed within 5 minutes of entering error mode, the vacuum will enter Sleep mode.

Suction

In the Wyze app, you can select Quiet, Standard, or Strong mode. Standard is the default mode.

Resume Cleaning Automatically

If the battery runs low during cleaning, the vacuum will automatically return to the charging station to charge itself. After it is charged to a certain level, it will resume where it previously stopped. If cleaning is manually ended during charging, the vacuum will not resume cleaning.

Scheduled Cleaning

You can schedule cleaning cycles through the Wyze app. The vacuum will begin cleaning at the designated time and then return to the charging station when it has finished.

Virtual Walls

You can set up an area that you don't want the vacuum to enter such as the bathroom, a storage room, under the coffee table, or anywhere else.

Map Memorization

When your vacuum leaves the charging station for the first time and completes a whole home cleaning, and returns to the charging station, it will save your home map and divide it into sections. This will allow you to select different areas to clean from the Wyze app.

Routine Maintenance

Dustbin

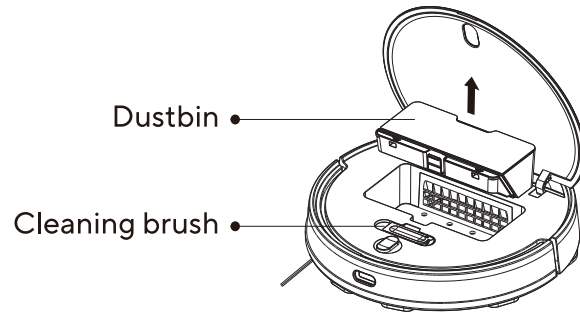

1. Open the top cover to remove the dustbin and the cleaning brush.

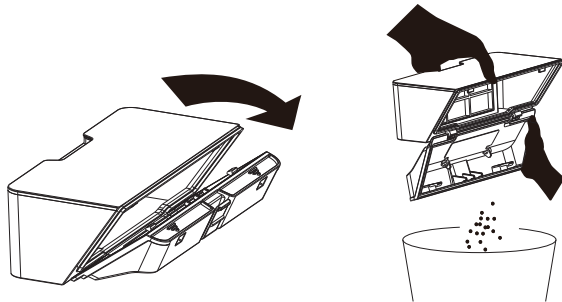

2. Open the dustbin and empty it.

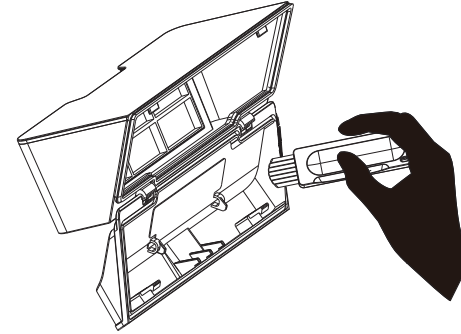

3. Use the cleaning brush to clean the dustbin, then close the lid.

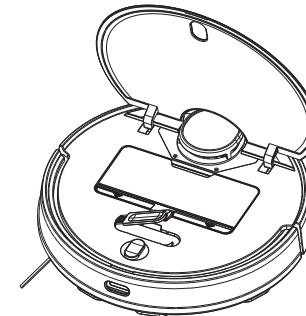

4. Reinstall the dustbin and cleaning brush before closing the cover.

Routine Maintenance

HEPA Filter

Pull off the cover like in the diagram below to remove the HEPA filter and clean it.

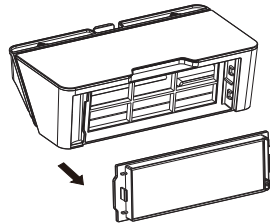

Main Brush

1. Release the lower clip to remove the cover for the main brush.
2. Remove the main brush and clean the bearing.
3. Clean the main brush.
4. Reinstall the main brush and bearing and then fasten the cover clip again.

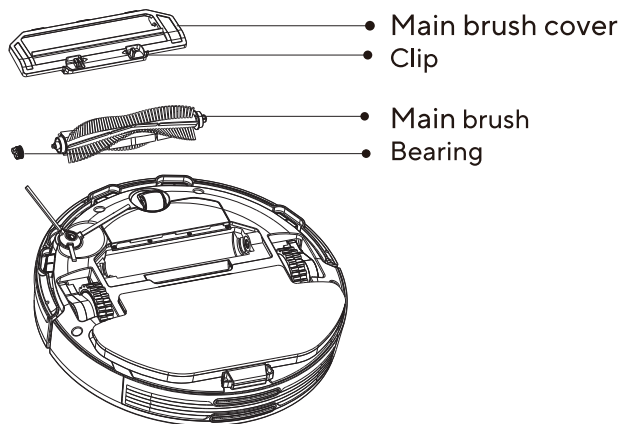

Edge Brush

Remove and clean the edge brush regularly.

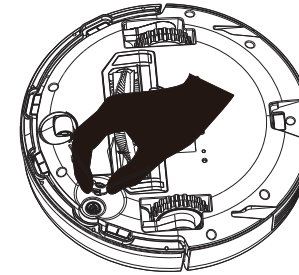

Cliff sensor

Clean the Cliff sensor regularly using a soft cloth.

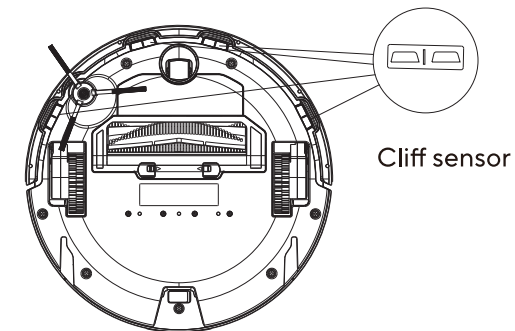

Note:

- Replace the main brush every 6-12 months for the best cleaning performance;
- Replace the HEPA filter every 3 months;
- Clean the HEPA filter with the cleaning brush regularly to avoid blockages;
- Replace the edge brush every 3 months for the best cleaning performance.

Basic Parameters

Robot Vacuum

Name	Parameter
Overall dimensions	Φ13.8in x 3.7in (Φ350mm x 94.5mm)
Product weight	Approximately 7.2lbs (3.3kg)
Rated voltage	14.6V ---
Rated power	33W
Battery capacity	3000mAh

Charging Station

Name	Parameter
Overall dimensions	6.1in x 2.9in x 3.9in (153.9mm x 74.6mm x 99.5mm)
Rated power	24W
Rated input	20V --- 1.2A
Rated output	20V --- 1.2A

Names and Contents of Hazardous Substances in the Product

Part name	Hazardous substances					
	Lead (Pb)	Mercury (Hg)	Cadmium (Cd)	Hexavalent Chromium (Cr VI)	Polybrominated Biphenyls (PBB)	Polybrominated Diphenyl ethers (PBDE)
Metals	X	○	○	○	○	○
Printed circuit boards	○	○	○	○	○	○
Plastics	○	○	○	○	○	○
Standard parts (screws, washers, etc.)	○	○	○	○	○	○
Other metal structural parts (motor, decorative parts, etc.)	○	○	○	○	○	○

○ : Indicates that the content of this hazardous substance does not exceed the percentage of reference value of presence.

X : Indicates that the restricted substance corresponds to the exemption.

Long-term use of the product will not cause harm to human health.



Marking for the restriction of the use of hazardous substances

Troubleshooting

Error prompt	Solution
The laser radar blocked.	Clear foreign objects around the laser radar or move the vacuum to a new position, then retry.
Cliff sensor soiled or blocked.	Wipe the cliff sensor with a soft cloth, then retry.
Magnetic field detected.	Move the vacuum to a new position, then retry.
Collision sensor blocked.	Check the collision strip. Clear any foreign objects or blockages, then retry.
Abnormal vacuum temperature.	The vacuum is too hot or cold. Let the vacuum reach room temperature, then retry.
Charging error.	Confirm that you're using the supplied power adapter, and the charging station is placed horizontally. Turn off the vacuum and unplug the charging station from power. Wipe the charging contacts with a dry cloth. Plug in the charging station, then retry.

Troubleshooting

Problem	Solution
Vacuum will not turn on	The battery level is too low. Connect the vacuum to the charging station. The ambient temperature is too low (<32°F) or too high (>122°F).
Vacuum won't start cleaning	The battery level is too low. Connect the vacuum to the charging station.
Vacuum cannot return to the charging station	There are obstacles near the charging station. Move the charging station to an obstacle-free area. The vacuum is too far from the charging station. Move the vacuum closer to the charging station.
Vacuum is malfunctioning	Turn off and restart the vacuum.
Abnormal sounds while cleaning	The main brush, edge brush or left/right wheel may be entangled with foreign objects. Turn off the vacuum and clear the brushes and wheels, then retry.
Poor cleaning performance	The dustbin is full. Empty the dustbin. The HEPA filter is blocked. Use the cleaning brush to clean it, then retry. The main brush is entangled with foreign objects. Clean the main brush, then retry.
Vacuum fails to connect to WiFi	WiFi signal is weak or inconsistent. Make sure the vacuum has a strong WiFi signal, and check for firmware updates in the Wyze app, then try again.
Fails to resume cleaning	Use the Wyze app to recharge. Vacuum will not resume cleaning if manually brought to the charging station.
Vacuum is not charging	Ensure that there is sufficient space around the charging station, and that the surfaces of the charging contacts are free from dust and coverage.
Scheduled cleaning failed	App sync issues. Scheduled cleanings may be interrupted. Confirm your Wyze app settings and check for firmware updates.
Vacuum remains offline	Confirm that the device has been successfully connected to the network and it is always within WiFi range.
Vacuum won't pair with the Wyze app	Ensure that the charging station and the vacuum are within WiFi range. Then reset your WiFi connection according to the steps described in the Instruction Manual (page 6).

Usage Restrictions

- This product is only intended for cleaning floors inside the home and should not be used in outdoor areas (e.g. balconies), on surfaces other than floors (e.g. sofas), or in commercial or industrial environments.
- Do not use the vacuum in environments without guardrails (e.g. duplex floors, balconies, or on top of furniture).
- Do not use the vacuum in environments outside of 32°F - 104°F or where any liquid or slime is on the floor.
- Remove all fragile items from the floor before use to prevent accidental damage.
- Store all fragile objects (such as vases or plastic bags) on the floor before use in case the vacuum gets blocked or damages the object by gently hitting it.
- Never allow pets or children to play with the vacuum. Keep pets and children away from the vacuum when it is running.
- Do not allow objects, children, or pets on top of the vacuum at any time.
- Do not use the vacuum to clean any burning objects (e.g. a lit cigarette).
- Do not use the vacuum to clean shag carpets. It is possible that some dark carpets will not be able to be cleaned.
- Do not use the vacuum to clean hard or sharp objects (e.g. broken glass or nails).
- Do not use the laser radar protective cover as a handle to move the device.
- Only do maintenance or clean the vacuum and charging station when they are turned off.
- Never spray liquid into the vacuum. Wipe the dustbin dry before replacing it after each cleaning.
- Do not place the vacuum upside down because it may damage the laser radar.
- Use the product only according to the Quick Start Guide and User Manual.

Battery and Charging

- Do not use any batteries, power adapters, or charging stations provided by a third party.
- Do not use non-rechargeable batteries.
- Never attempt to remove, repair, or modify the battery or charging station.
- Do not place the charging station near heat sources (e.g. portable heaters, electric baseboards).
- Do not use a wet cloth or any liquid to clean this product.
- Do not throw away dead batteries. Please dispose of them using an official battery recycling organization.
- Only transport the vacuum when it is turned off and in the original packaging to protect it.
- If the product will not be used for a long time, fully charge the vacuum, turn it off, and store it in a cool, dry place. Recharge the vacuum at least once a month to avoid damaging the battery.

The laser radar of this product complies with the requirements of IEC 60825 - 1:2014 on the safety of Class 1 laser products. It will not produce laser radiation that is harmful to human health.

Warranty Certificate

Limited Warranty

Wyze warrants to the original owner of the Product that the Product will be free from defects in materials and workmanship for a period of one (1) year from the date you purchased your Product from Wyze or an authorized retailer (the "Warranty Period") Wyze will, at its sole option, either (a) repair or replace any defective Product or component or (b) accept the return of the Product and refund the money actually paid by the original purchaser for the Product to the payment method used by the purchaser. This warranty is not transferable and applies only to the original purchaser.

Repairs or replacements may be made with new or refurbished products or components, at Wyze's sole discretion. If the Product or a component incorporated in that Product is no longer available, Wyze may, at Wyze's sole discretion, replace the Product with the available model nearest to the original model's form, functionality, and performance.

Any repaired or replacement Product received by you will be covered by the Limited Warranty for the longer of (a) three months from the date of replacement or repair or (b) the remaining Warranty Period on the replaced or repaired Product.

What the Limited Warranty Does Not Cover

This Limited Warranty does not cover the following:

- Products submitted after the expiration of the Warranty Period
- Products submitted without valid proof of purchase
- Products returned from outside countries where Wyze ships Products
- Products purchased from unauthorized retailers
- Products provided by Wyze or its designee for promotional purposes without charge
- Products on which repairs have been attempted
- Products damaged due to misuse, abuse, negligence, or other use not in accordance with the Product's Quick Start Guide or other instructions provided by Wyze
- Products that have been modified

For additional information, please visit:

<https://wyze.com/return-warranty-policy#c>

FCC WARNING

This device complies with part 15 of the FCC Rules. Operation is subject to the following two conditions: (1) this device may not cause harmful interference, and (2) this device must accept any interference received, including interference that may cause undesired operation. Any changes or modifications not expressly approved by the party responsible for compliance could void the user's authority to operate the equipment.

NOTE: This equipment has been tested and found to comply with the limits for a Class B digital device, pursuant to Part 15 of the FCC Rules. These limits are designed to provide reasonable protection against harmful interference in a residential installation. This equipment generates, uses and can radiate radio frequency energy and, if not installed and used in accordance with the instructions, may cause harmful interference to radio communications. However, there is no guarantee that interference will not occur in a particular installation.

If this equipment does cause harmful interference to radio or television reception, which can be determined by turning the equipment off and on, the user is encouraged to try to correct the interference by one or more of the following measures:

- Reorient or relocate the receiving antenna.
- Increase the separation between the equipment and receiver.
- Connect the equipment into an outlet on a circuit different from that to which the receiver is connected.
- Consult the dealer or an experienced radio/TV technician for help. The device has been evaluated to meet general RF exposure requirement. The device can be used in portable exposure condition without restriction.

FCC ID: 2AUIU-WVCR200S

IC Caution

This device complies with Industry Canada licence-exempt RSS standard(s).

Operation is subject to the following two conditions:

(1) This device may not cause interference, and (2) This device must accept any interference, including interference that may cause undesired operation of the device.

Le présent appareil est conforme aux CNR d'Industrie Canada applicables aux appareils radio exempts de licence.

L'exploitation est autorisée aux deux conditions suivantes:

(1) l'appareil ne doit pas produire de brouillage, et (2) l'utilisateur de l'appareil doit accepter tout brouillage radioélectrique subi, même si le brouillage est susceptible d'en compromettre le fonctionnement.

IC: 25466-WVCR200S

IMPORTANT SAFETY INSTRUCTIONS

READ ALL INSTRUCTIONS BEFORE USING THIS APPLIANCE. SAVE THESE INSTRUCTIONS For Household use only

When using an electrical appliance, basic precautions should always be followed, including the following:

WARNING: Read all safety warnings and instructions. Failure to follow the warnings and instructions may result in electric shock, fire or serious injury.

1. Do not allow to be used as a toy. Close attention is necessary when used by or near children.
2. Clear the area to be cleaned. Remove power cords and small objects from the floor that could entangle the Appliance. Tuck rug fringe under the rug base, and lift items such as curtains and tablecloths off the floor.
3. If there is a drop off in the cleaning area due to a step or stairs, you should operate the Appliance to ensure that it can detect the step without falling over the edge. It may become necessary to place a physical barrier at the edge to keep the unit from falling. Make sure the physical barrier is not a trip hazard.
4. Only use the Appliance as described in this manual. Only use attachments recommended or sold by the manufacturer.
5. Please make sure your power supply voltage matches the power voltage marked on the Charging Station.
6. Do not handle plug or appliance with wet hands.
7. Non-rechargeable batteries are prohibited.
8. Do not use without dustbin and/or HEPA filters in place.
9. Do not operate the appliance in an area where there are lit candles or fragile objects on the floor to be cleaned.
10. Do not use and/or store in extremely hot or cold environments (below $-5^{\circ}\text{C}/23^{\circ}\text{F}$ or above $40^{\circ}\text{C}/104^{\circ}\text{F}$). Please charge appliance in temperature above $0^{\circ}\text{C}/32^{\circ}\text{F}$ and below $40^{\circ}\text{C}/104^{\circ}\text{F}$.
11. Keep hair, loose clothing, fingers, and all parts of body away from

any openings and moving parts.

12. Do not operate the Appliance in a room where an infant or child is sleeping.
13. For INDOOR use ONLY. Do not use the Appliance in outdoor, commercial or industrial environments. Do not use Appliance on wet surfaces or surfaces with standing water.
14. Do not allow the Appliance to pick up large objects like stones, large pieces of paper or any item that may clog the Appliance.
15. Do not use Appliance to pick up flammable or combustible materials such as gasoline, printer or copier toner, or use in areas where they may be present.
16. Do not use Appliance to pick up anything that is burning or smoking, such as cigarettes, matches, hot ashes, or anything that could cause a fire.
17. Do not put any object into openings. Do not use with any opening blocked; keep free of dust, lint, hair, and anything that may reduce air flow.
18. Take care not to damage the power cord. Do not pull on or carry the Appliance or Charging Station by the power cord, use the power cord as a handle, close a door on the power cord, or pull power cord around sharp edges or corners. Do not run Appliance over the power cord. Keep power cord away from hot surfaces. Do not unplug by pulling on cord. To unplug, grasp the plug, not the cord.
19. If the power cord is damaged, it must be replaced by the manufacturer or its service agent in order to avoid hazards.
20. Do not use the Charging Station if it is damaged.

21. Do not use with a damaged power cord or plug. Do not use the Appliance or Charging Station if it is not working properly, has been dropped, damaged, left outdoors, or come in contact with water. It must be repaired by the manufacturer or its service agent in order to avoid hazards.

22. Turn OFF the power switch before cleaning or maintaining the Appliance. Turn off all controls before unplugging.

23. The plug must be removed from the receptacle before cleaning or maintaining the Charging Station.

24. Remove the Appliance from the Charging Station, and turn OFF the power switch to the Appliance before removing the battery for disposal of the Appliance.

25. The battery must be removed and discarded according to local laws and regulations before disposal of the Appliance.

26. Please dispose of used batteries according to local laws and regulations.

27. Do not incinerate the Appliance even if it is severely damaged. The batteries can explode in a fire.

28. When not using the Charging Station for a long period of time, please unplug it.

29. The Appliance must be used in accordance with the directions in this Instruction Manual. Robot cannot be held liable or responsible for any damages or injuries caused by improper use.

30. To prevent unintentional starting, ensure the switch is in the OFF position before connecting to a battery pack or picking up/carrying the appliance. Avoid touching the switch and induction strips while picking up/carrying the appliance.

31. When battery pack is not in use, keep it away from other metal objects, like paper clips, coins, keys, nails, screws or other small metal objects, that can make a connection from one terminal to another. Shorting the battery terminals together is a burn/fire risk.

32. Under abusive conditions, liquid may be ejected from the battery; avoid contact. If contact accidentally occurs, flush with water. If liquid contacts eyes, additionally seek medical help. Liquid ejected from the battery may cause irritation or burns.

33. Do not use a battery pack or appliance that is damaged or modified. Damaged or modified batteries may exhibit unpredictable behavior resulting in fire, explosion or risk of injury.

34. Do not expose a battery pack or the appliance to fire or excessive temperatures. Exposure to fire or temperatures above 130°C/265°F may cause an explosion. Follow all charging instructions and do not charge the battery pack or appliance outside of the temperature range specified in the instructions. Charging improperly or at temperatures outside of the specified range may damage the battery and increase the risk of fire.

35. Follow all charging instructions and do not charge the battery pack or appliance outside of the temperature range specified in the instructions. Charging improperly or at temperatures outside of the specified range may damage the battery and increase the risk of fire.

36. Have servicing performed by a qualified repair person using only identical replacement parts. This will ensure that the safety of the product is maintained.

37. Do not modify or attempt to repair the appliance or the battery pack (as applicable) except as indicated in the instructions for use and care.

38. Remove cords from other appliances from any areas being cleaned.

39. Do not operate the appliance in a room that has lit candles on furniture that the appliance may accidentally hit or bump into.

40. Do not allow children to sit on the appliance.

41. Recharge only with the charger specified by the manufacturer. A charger that is suitable for one type of battery pack may create a risk of fire when used with another battery pack.

42. Use appliances only with specifically designated battery packs. Use of any other battery packs may create a risk of injury and fire.

43. The appliance contains batteries that are only replaceable by skilled persons. To replace the appliance's battery, please contact Customer Service.

44. If the appliance will not be used for a long period of time, fully charge the appliance and power OFF for storage. Unplug and store the Charging Station in a clean, dry place.

WYZE™

WYZE LABS, INC.

5808 Lake Washington Blvd NE, Suite 300, Kirkland WA 98033

www.wyze.com